

NOTE: All Assembly Order Numbers are for bead plate parts unless noted otherwise.

	Description	Assembly Order No.
Style 19	Blind nuts, 1/4 BSP	W01-M58-6008
	Blind nuts, 1/4 BSP, bumper	W01-M58-6373
Two Ply Bellows	Blind nuts, 3/4 BSP	W01-M58-6011
	Blind nuts, 3/4 BSP, bumper	W01-M58-6372
	Countersunk steel bead rings, 40 mm bolts, nuts, washers	W01-M58-6975
	Rubber bellows only	W01-358-0134
Assembly weight (bead plate version, no bumper)		4.45 kg.
Force to collapse to minimum height (@ 0 BAR)		40 N.

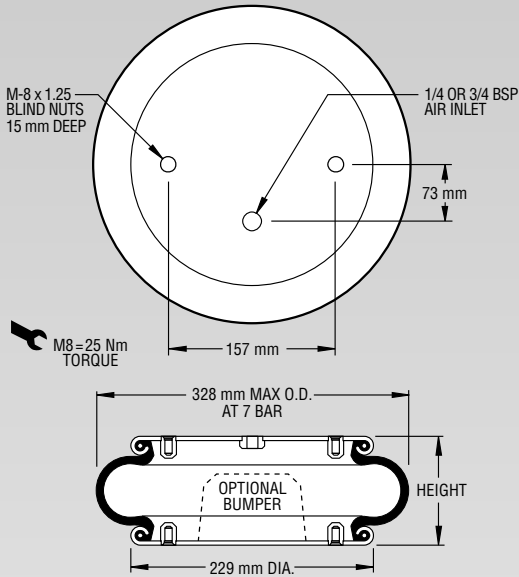

NOTE: A bead plate part is shown. This part is also available with bead rings. See pages 8-10 for explanation.

Gauge Pressure (BAR)	Load (kN)	Spring Rate (kN/m)	Natural Frequency Hz
3	10.49	290	2.62
4	14.46	383	2.57
5	18.21	471	2.54
6	22.34	559	2.49
7	26.15	641	2.47

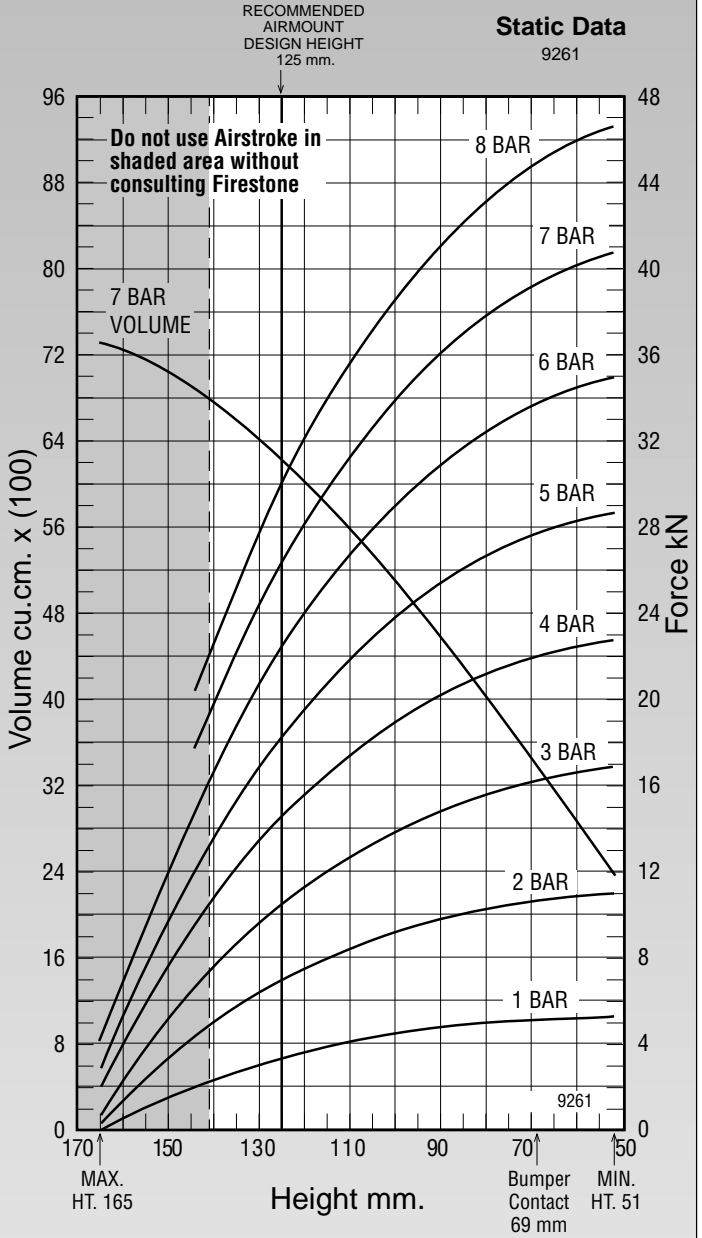

See page 12 for instructions on how to use chart.

Assembly Height (mm)	Volume @ 7 BAR (cu cm)	EFF Area @ 7 BAR (cm sq)	kN Force				
			@ 3 BAR	@ 4 BAR	@ 5 BAR	@ 6 BAR	@ 7 BAR
130	6379	345	9.61	13.28	16.74	20.60	24.15
120	6004	398	11.24	15.49	19.48	23.85	27.87
110	5555	444	12.67	17.39	21.84	26.65	31.10
100	5093	482	13.85	18.90	23.74	28.92	33.71
90	4566	513	14.87	20.18	25.35	30.86	35.94
80	4048	539	15.67	21.16	26.59	32.38	37.69
70	3474	559	16.27	21.93	27.58	33.60	39.13
60	2923	574	16.68	22.48	28.26	34.45	40.15