

NOTE: All Assembly Order Numbers are for bead ring parts unless noted otherwise.

	Description	Assembly Order No.
Style 119	Ribbed neck aluminum bead rings (equal spacing), 45 mm bolts, nuts, washers	W01-M58-6974
Two Ply Bellows	Rubber bellows only	W01-358-0119
	Rolled plate assembly, 1/2 blind nuts, 3/4 BSP	SEE NOTE BELOW
Assembly weight.....		5.98 kg.
Force to collapse to minimum height (@ 0 BAR)		76 N.

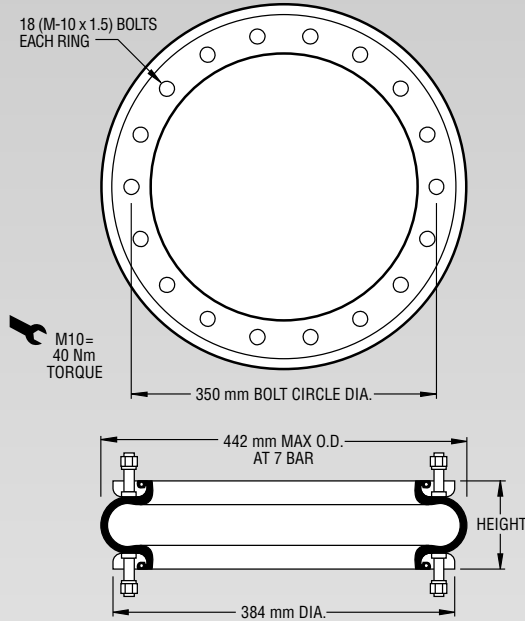

NOTE: A bead plate part is shown. This part is also available with rolled plates. See page 11 for explanation.

Gauge Pressure (BAR)	Load (kN)	Spring Rate (kN/m)	Natural Frequency Hz
3	26.86	599	2.35
4	36.82	766	2.27
5	46.53	934	2.23
6	57.15	1109	2.20
7	66.80	1269	2.17

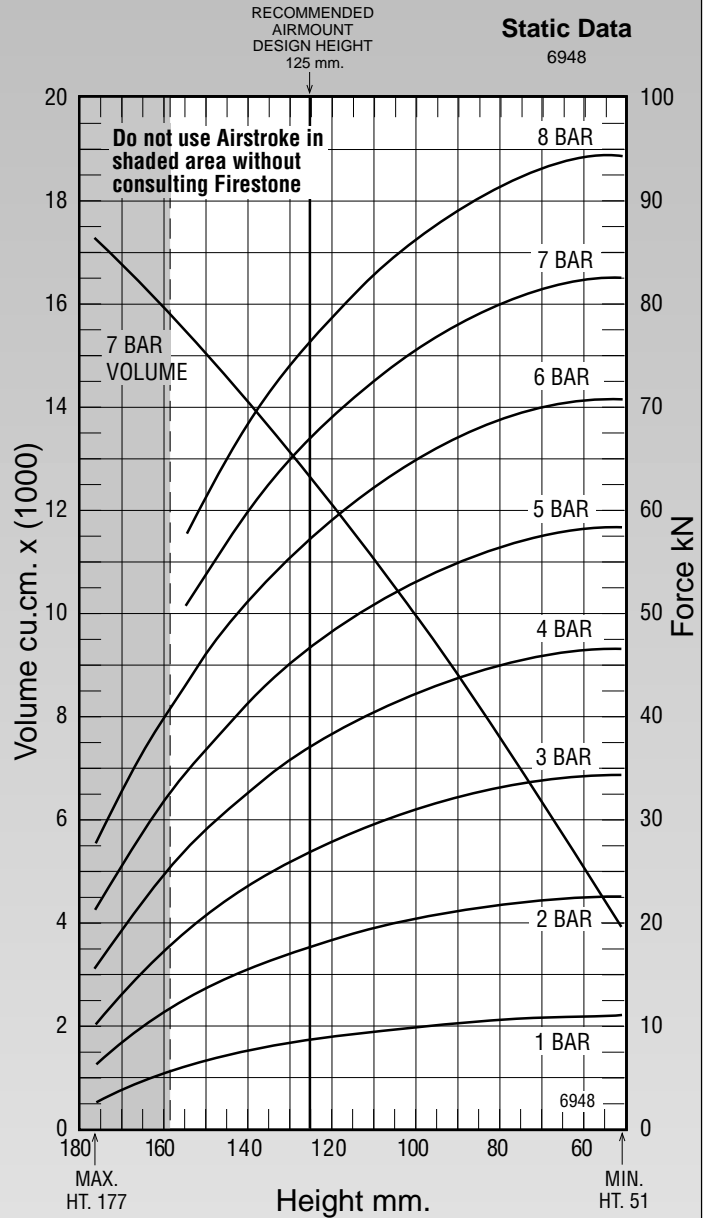

See page 12 for instructions on how to use chart.

Assembly Height (mm)	Volume @ 7 BAR (cu cm)	EFF Area @ 7 BAR (cm sq)	kN Force				
			@ 3 BAR	@ 4 BAR	@ 5 BAR	@ 6 BAR	@ 7 BAR
140	14081	847	23.26	32.31	40.96	50.59	59.29
130	13097	922	25.78	35.46	44.84	55.17	64.52
120	12133	982	27.78	37.99	47.98	58.85	68.74
110	11058	1033	29.48	40.18	50.67	62.00	72.34
100	10008	1075	30.83	41.97	52.85	64.53	75.23
90	8840	1110	31.99	43.53	54.73	66.70	77.72
80	7704	1139	32.96	44.81	56.25	68.45	79.72
70	6445	1162	33.79	45.85	57.48	69.86	81.34