

1. Raise vehicle and place jack stands under frame.
2. Remove the wheel and tire assemblies.
3. Remove lower shock absorber attaching bolts (Figure 1, item 1).
4. Remove lower springs retaining strap and bolts (Figure 1, item 2).
5. Remove stabilizer bar upper link retaining nuts, washers and bushings (Figure 2, item 1).
6. It will be necessary to remove the bolt on one end of the lower control arm to remove the coil spring. On some models there is an adjustable cam for suspension adjustment. Remove the opposite (non-adjustable) end bolt. If you find it necessary to remove the adjustable end bolt, the front suspension will have to be aligned.
7. Remove track bar attaching bolt (Figure 2, item 2).
8. Carefully lower axle and observe the brake lines being cautious not to strain them.
9. Using a pair of channel lock pliers, reach in through the turns of the coil to unscrew and remove the rubber jounce bumper (Figure 2, item 3).
10. Mark the index location of the coil spring end on the lower seat. Remove coil spring by lifting off the seat and pulling out toward rear of vehicle.
11. Drill 3/4" hole in center of lower spring seat using indentation as a guide. CAUTION - The hole must be no less than 3/4" and centered to properly nest the air cylinder valve base and prevent wear damage (Figure 3).
12. Mount the protector in place of the jounce bumper using the hex head bolt (Figure 4).
13. Insert air cylinder into coil spring with stem located at the bottom.
14. Install coil spring and air cylinder assembly. Be sure to nest inflation valve base in drilled hole in the spring seat.
15. Install Air Line kit. User may select either Dual Air Line or Tee Air Line option depending on use of vehicle. Dual Air Line installation is recommended to allow side-to-side leveling for uneven load (see Air Line installation instructions before continuing).

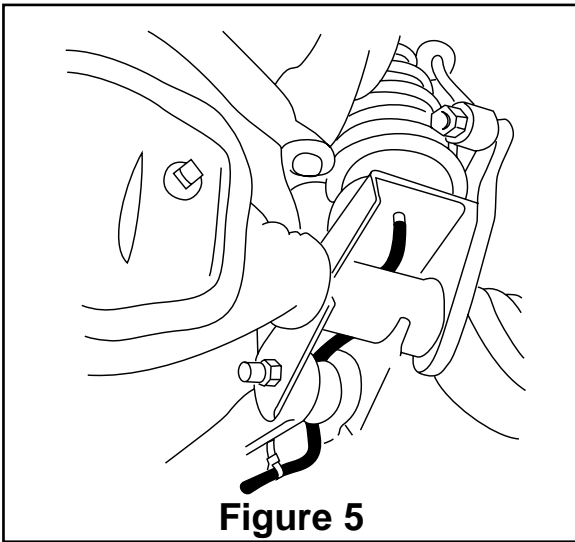

Figure 5

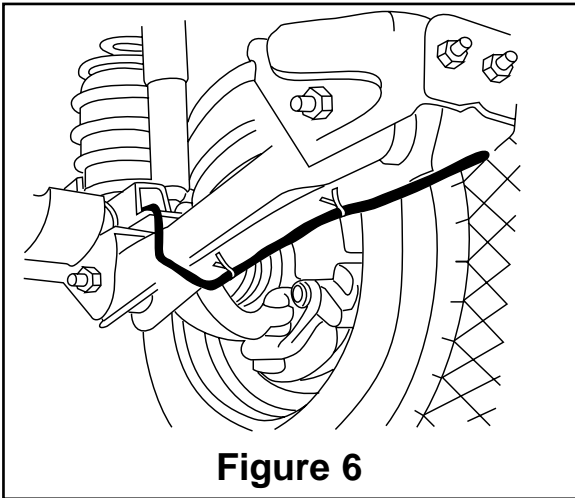
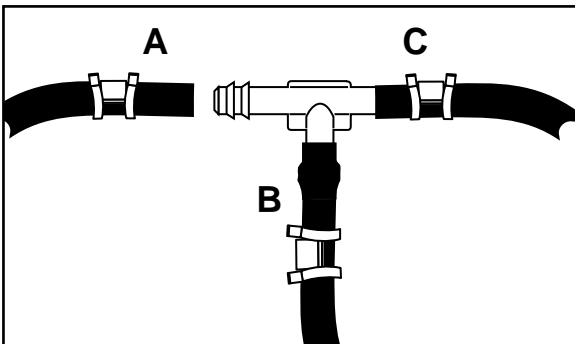

Figure 6



Use this procedure for all air line connections:
A. Slide air line clamp onto the air line
B. Push the air line over the barbed stem.
C. Compress the ears on the air line clamp with pliers and slide it forward to fully cover the barbed section.

Figure 7

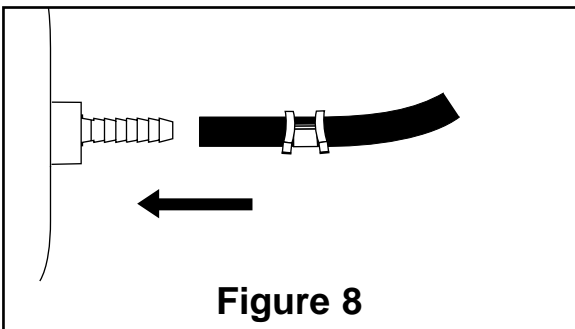

Figure 8

16. Carefully raise axle.
17. Replace lower spring retaining strap and bolts.
18. Replace stabilizer bar upper link retaining nuts, washers and bushings (torque 14 ft. lbs.).
19. Replace lower shock absorber attaching bolts (torque 25 ft. lbs.).
20. Replace track bar attaching bolt (torque 55 ft. lbs.).
21. Replace forward lower control arm attaching bolts (torque 133 ft. lbs.).
22. Repeat on other side of vehicle.
23. Inflate Air Springs to 50 p.s.i. Check for air leaks at all fittings and valve core with soapy/water solution and making any necessary repairs.
24. Replace wheels, remove safety stands and carefully lower vehicle to ground.
25. Deflate Air Springs in 10 p.s.i. intervals to determine best ride and handling. A minimum of 10 p.s.i. air pressure must be maintained to help prevent bottoming-out on large bumps, chuckholes, etc, and to prevent premature cylinder failure.
26. Read Maintenance/Operation Tips for proper care of your air Cylinders (see page 4).

Tea air line installation recommended unless weight in vehicle varies from one side to the other and unequal pressures are needed to level the load. Dual air lines are used in this case.

TEE AIR LINE ROUTING

TO PREVENT AIR LINE FROM MELTING, KEEP IT AT LEAST EIGHT INCHES FROM EXHAUST SYSTEM.

- A. Locate desired tee location on the frame rail or cross member.
- B. Determine and cut adequate length of air line to reach from tee to left and right side on air cylinders.

CAUTION: LEAVE SUFFICIENT AIR LINE SLACK TO PREVENT ANY STRAIN ON FITTING DURING AXLE MOTIONS.

- C. Slide air line clamp onto the air line.
- D. Push the air line over one side of the tee until all the barbs are covered. Repeat procedure for other leg of tee (Figure 7). With pliers slide the air line clamp forward until it fully covers the barbed section. Repeat for other leg of tee.
- E. Route along cross member and either lower control arm or upper spring seat to air cylinder.
- F. Insert air line through spring seat and slide on air line clamp.

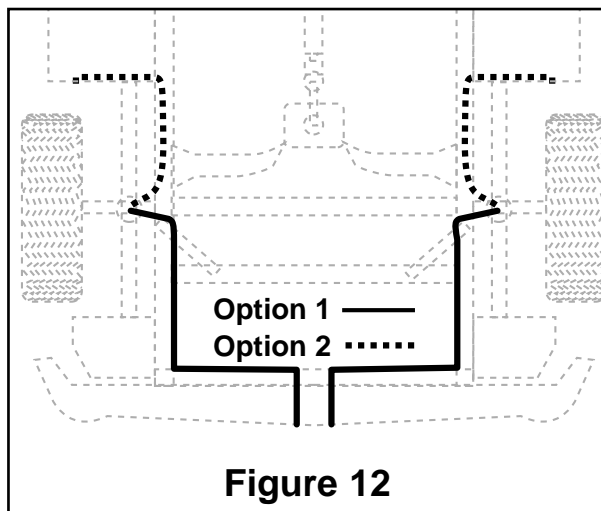
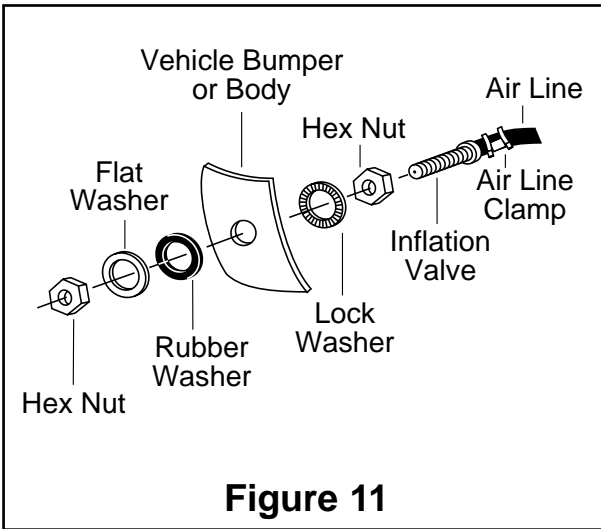
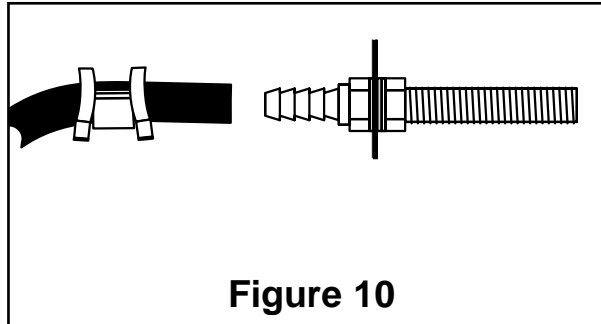
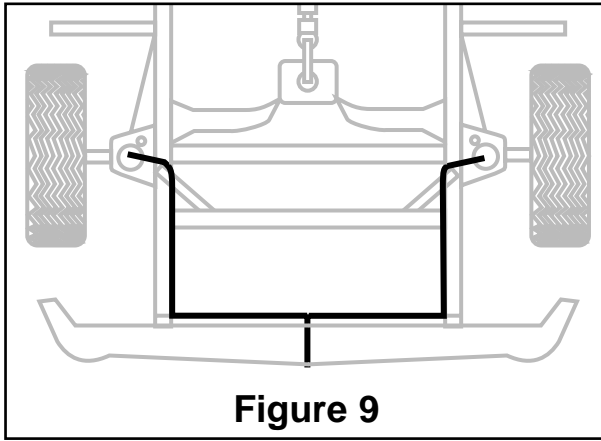

- G. Push the air line onto the stem, covering all the barbs. With pliers slide the air line clamp upward until it fully covers the barbed section.
- H. Push the remaining air line over the last fitting on tee and route along frame to desired inflation valve location (Figure 9). Attach with plastic straps or wire.
- I. Select a location for inflation valve in the hood release, front bumper, fender flange or behind the license plate, assuring that the valve will be protected and accessible with an air hose.
- J. Drill a 5/16" hole for inflation valve and mount as in illustration (Figure 11). Rubber washer is for outside weather seal.
- K. Slide air line clamp over the air line. Push air line onto fitting covering all barbs, with pliers slide the air line clamp forward until it fully covers the barbed section (Figure 10).
- L. Raise axle or lower body until air cylinders lightly touch upper spacer and lower spring seat.

DO NOT INFLATE AIR CYLINDERS BEFORE READING MAINTENANCE & OPERATING TIPS.

M. Continue with step 16, page 1.

DUAL AIR LINE ROUTING

TO PREVENT AIR LINE FROM MELTING, KEEP IT AT LEAST EIGHT INCHES FROM EXHAUST SYSTEM.

- A. Select a location for inflation valve in the hood release, front bumper, fender flange or behind the license plate, assuring that the valve will be protected and accessible with an air hose.
- B. Determine and cut adequate length of air line to reach from valve location to left side air cylinder.

CAUTION: LEAVE SUFFICIENT AIR LINE SLACK TO PREVENT ANY STRAIN ON VALVE STEM DURING NORMAL AXLE MOTIONS.

- C. Insert the air line through the lower spring seat.
- D. Slide air line clamp onto the cut air line.
- E. Push the air line onto the stem, covering all the barbed section (Figure 8). With pliers slide the air line clamp forward until it fully covers barbed section.
- F. Repeat process for right side.
- G. Drill 5/16" hole for inflating valves and mount as illustrated. Rubber washer is for outside weather seal (Figure 11).
- H. Route air line along control arm and frame to inflation valve location and cut off excess.

- I. Slide air line clamp onto the air line and push the air line over the fitting, covering all the barbs. With pliers slide the air line clamp forward until it fully covers the barbed section (Figure 10).
- J. Raise axle or lower body until air cylinders lightly touch upper spacer and lower spring seat.
- K. Attach shock absorbers if removed earlier in the installation.

DO NOT INFLATE AIR CYLINDERS BEFORE READING MAINTENANCE & OPERATING TIPS.

- L. Continue with step 16, page 1.

FAILURE TO MAINTAIN MINIMUM PRESSURE WILL VOID THE WARRANTY

MINIMUM AIR PRESSURE 10 P.S.I.	MAXIMUM AIR PRESSURE 50 P.S.I.
<p>MAINTENANCE TIPS:</p> <ol style="list-style-type: none"> 1. Check pressure weekly! 2. Always maintain at least 10 p.s.i. air pressure to prevent chafing or coil pinch. 3. If you develop an air leak in the system, use a soapy/water solution to check all air line connections and the valve core before removing cylinder. <p>OPERATING TIPS:</p> <ol style="list-style-type: none"> 1. Inflate your air springs to 50 p.s.i. before adding the payload. This will allow the air cylinder to properly mesh with the coil spring. After vehicle is loaded, adjust your air pressure (down) to level the vehicle and for ride comfort. 2. When you are carrying a payload it will be helpful to increase the tire inflation pressure in proportion to any overload condition. We recommend a 2 p.s.i. increase above normal (not to exceed tire manufacturers maximum) for each 100 lbs. additional load on the axle. 	
<div style="display: flex; justify-content: space-between; align-items: center;"> <div data-bbox="250 1625 561 1829">  </div> <div data-bbox="634 1633 1187 1667" style="text-align: center;"> <p><i>Thank you for purchasing Air Lift Products</i></p> </div> </div> <div style="text-align: center; margin-top: 20px;"> <p>AIR LIFT COMPANY P.O. BOX 80167 Lansing, MI 48908-0167</p> </div>	
<p>FOR TECHNICAL ASSISTANCE CALL 1-800-248-0892</p>	
<p>Caution: DO NOT EXCEED THE VEHICLE MANUFACTURERS MAXIMUM GROSS VEHICLE WEIGHT RATING.</p>	